

89H5@<9' 89' 9GH575' \$%
D# D=@5F 89' %1% fil &t
G9A 9G75#5

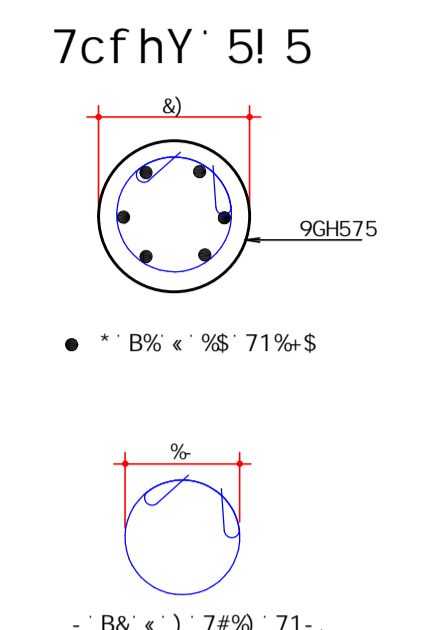

89H5@<9' 89' 9GH575' \$&
D# D=@5F 89' %& fil (t
G9A 9G75#5

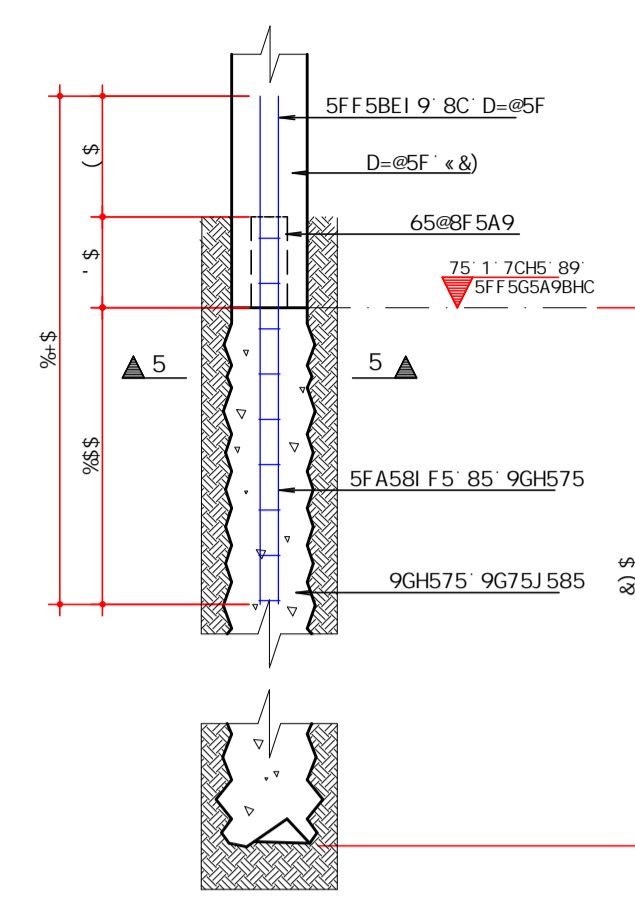
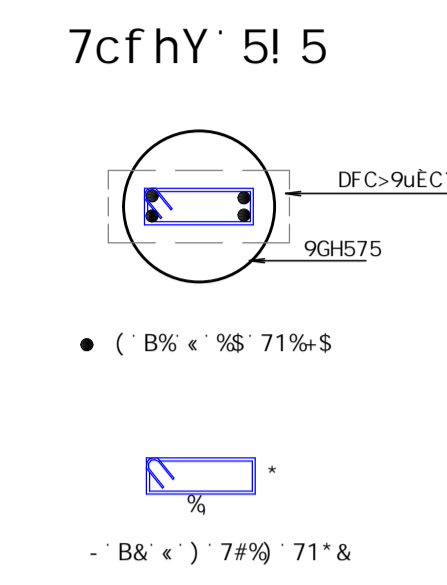
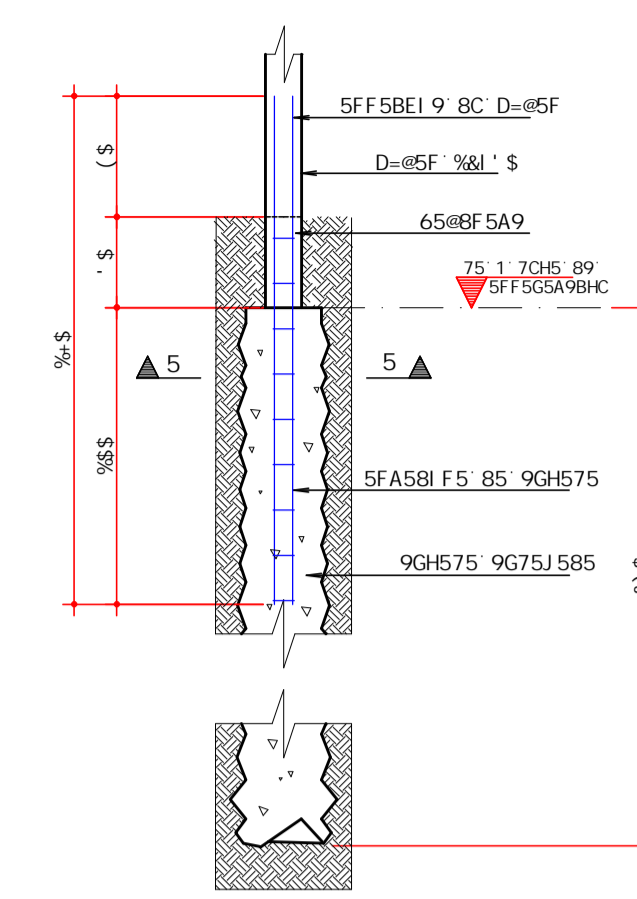

89H5@<9' 89' 9GH575' '\$'
D# D=@5F 89' %&I ' \$ fil &t
G9A 9G75#5

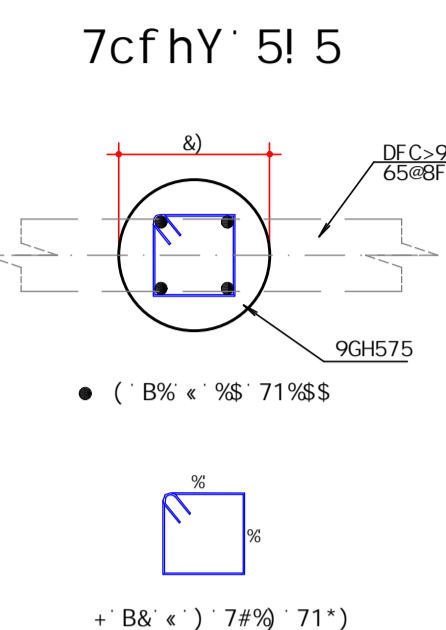
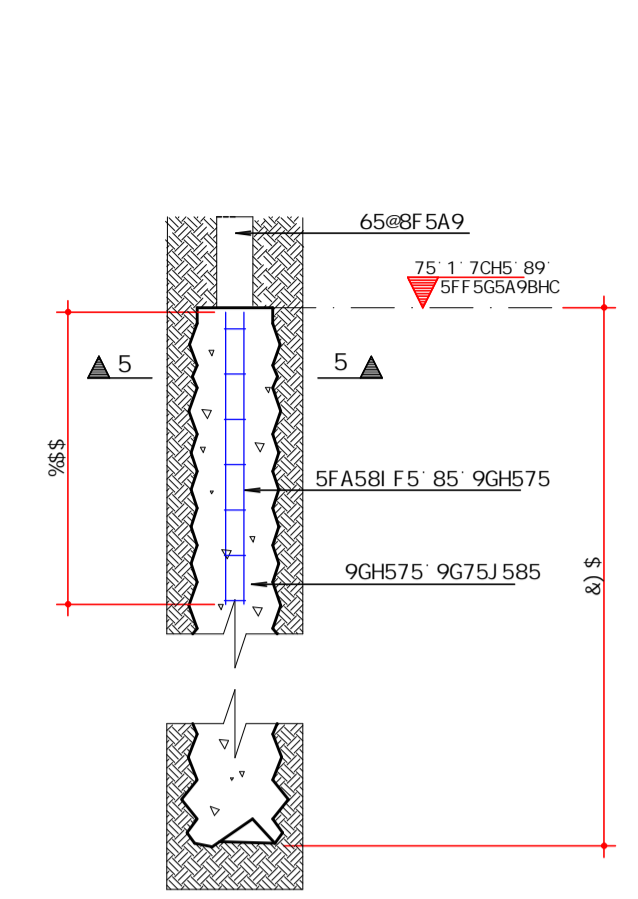

89H5@<9' 89' 9GH575' \$(
9GH575 G9A D=@5F fil t
G9A 9G75#5

H569@5' 89' 5uC' 85G' 9GH575G						
5uC	DCG	6=H flat	EI 5BH	7CADF=A9BHC	I B=H rivet	HCH5@ rivet
9GH575 \$%	fil &t	fil &t	fil &t	fil &t	fil &t	fil &t
9GH575 \$&	fil (t	fil (t	fil (t	fil (t	fil (t	fil (t
9GH575 \$'	fil &t	fil &t	fil &t	fil &t	fil &t	fil &t
9GH575 \$(fil t	fil t	fil t	fil t	fil t	fil t
9GH575 \$%	fil &t	fil &t	fil &t	fil &t	fil &t	fil &t
9GH575 \$&	fil (t	fil (t	fil (t	fil (t	fil (t	fil (t
9GH575 \$'	fil &t	fil &t	fil &t	fil &t	fil &t	fil &t
9GH575 \$(fil t	fil t	fil t	fil t	fil t	fil t
9GH575 \$%	fil &t	fil &t	fil &t	fil &t	fil &t	fil &t
9GH575 \$&	fil (t	fil (t	fil (t	fil (t	fil (t	fil (t
9GH575 \$'	fil &t	fil &t	fil &t	fil &t	fil &t	fil &t
9GH575 \$(fil t	fil t	fil t	fil t	fil t	fil t
9GH575 \$%	fil &t	fil &t	fil &t	fil &t	fil &t	fil &t
9GH575 \$&	fil (t	fil (t	fil (t	fil (t	fil (t	fil (t
9GH575 \$'	fil &t	fil &t	fil &t	fil &t	fil &t	fil &t
9GH575 \$(fil t	fil t	fil t	fil t	fil t	fil t

5uC	DCG	6=H	EI 5BH	7CADF=A9BHC	HCH5@
J%	fil &t	fil &t	fil &t	fil &t	fil &t
J&	fil (t	fil (t	fil (t	fil (t	fil (t
J'	fil &t	fil &t	fil &t	fil &t	fil &t
J(fil t	fil t	fil t	fil t	fil t
J)	fil &t	fil &t	fil &t	fil &t	fil &t
J*	fil &t	fil &t	fil &t	fil &t	fil &t
J+	fil &t	fil &t	fil &t	fil &t	fil &t
J,	fil &t	fil &t	fil &t	fil &t	fil &t
J-	fil &t	fil &t	fil &t	fil &t	fil &t
J%\$	fil &t	fil &t	fil &t	fil &t	fil &t

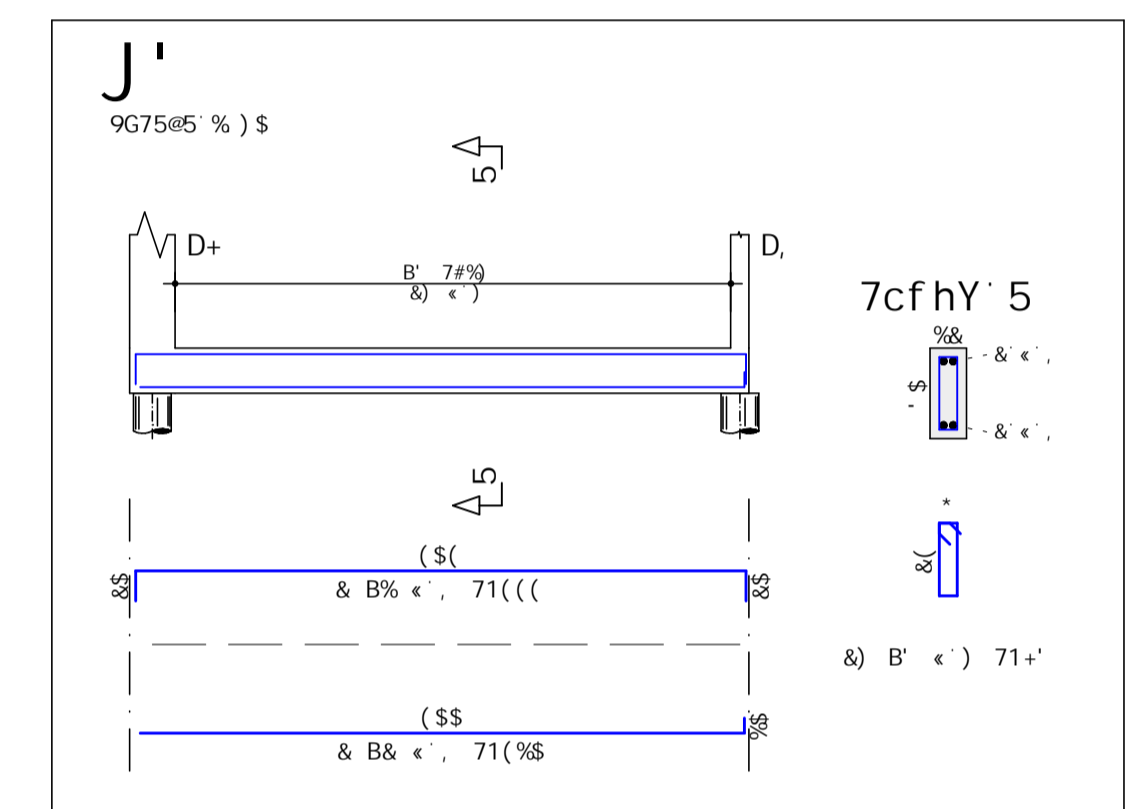
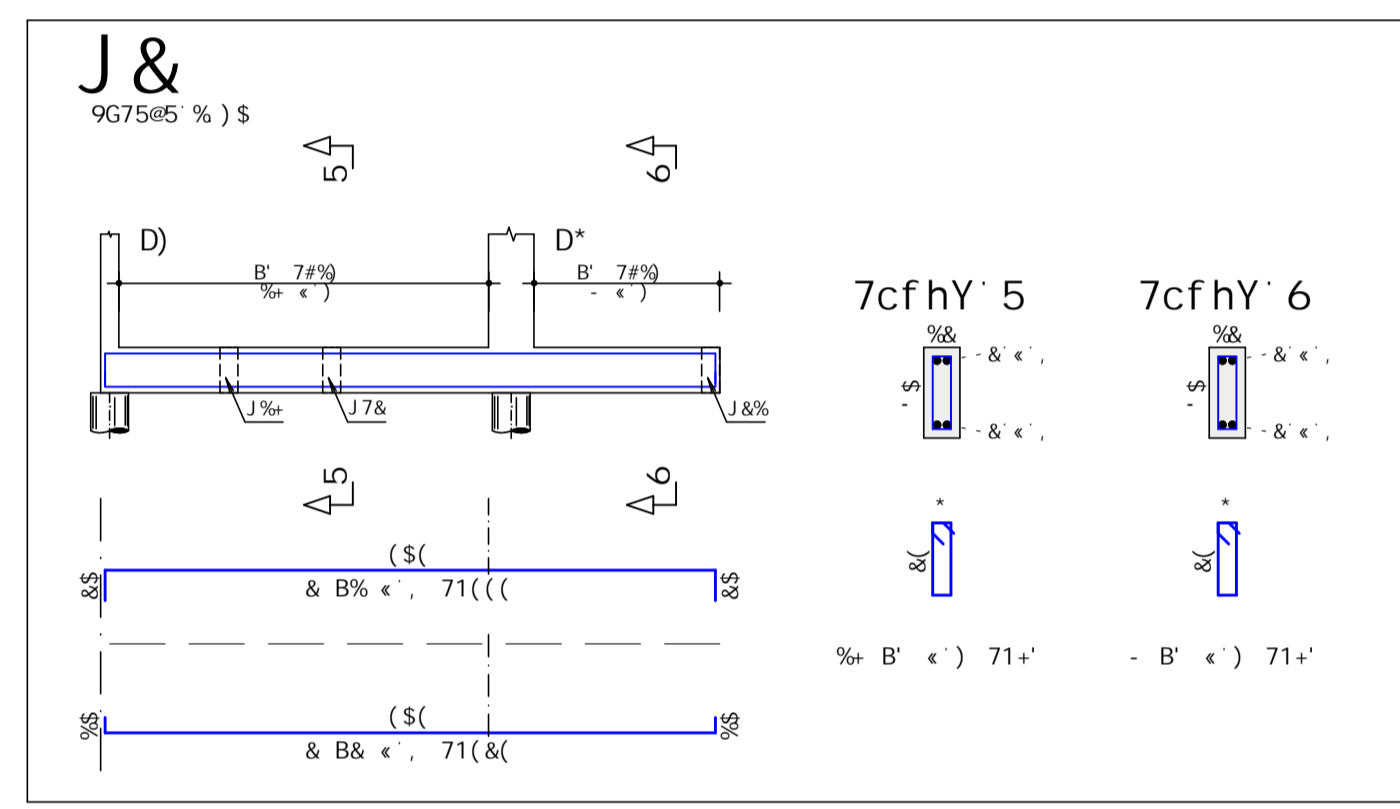
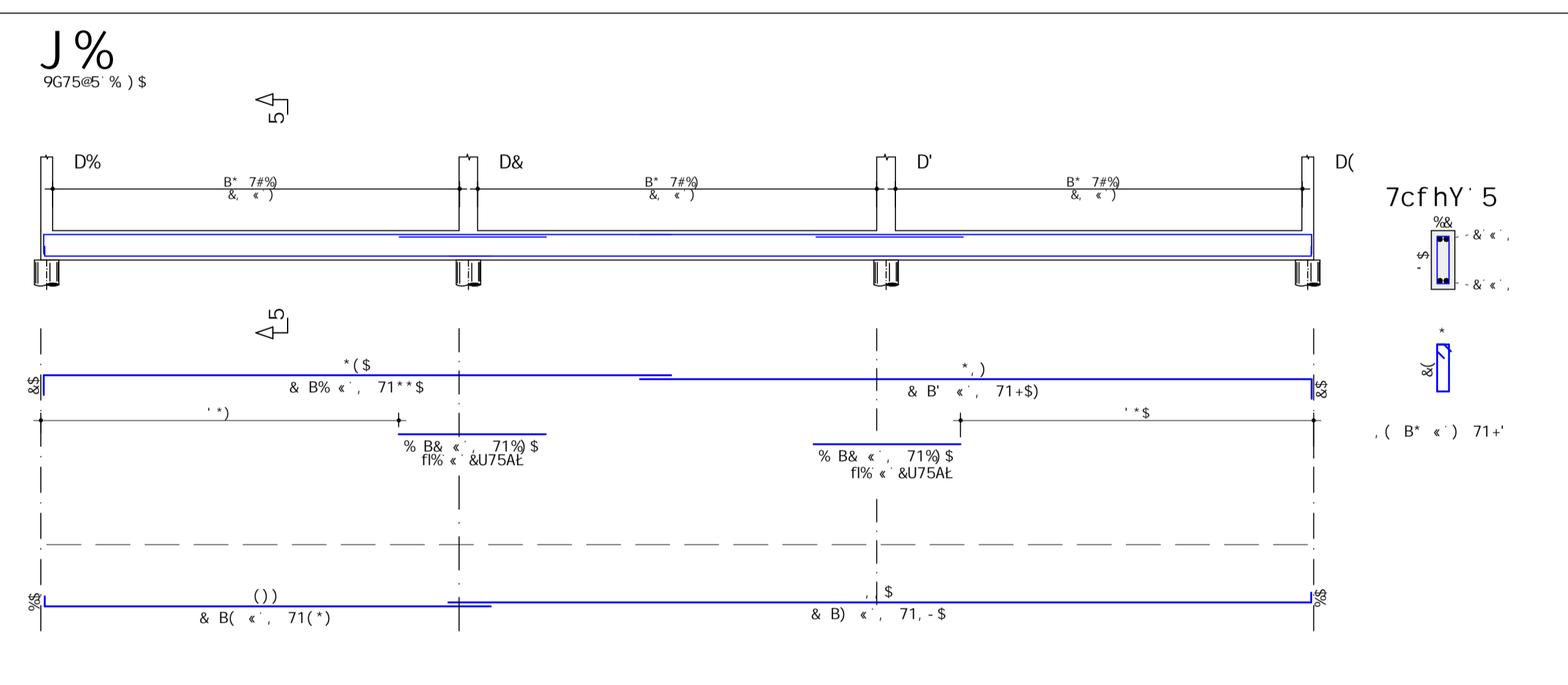

5uC	F9GI AC 89' 5uC	7CADF	D9GC
DYgc HchU	\$5 1	+	Z
DYgc HchU	\$5 1	+	Z

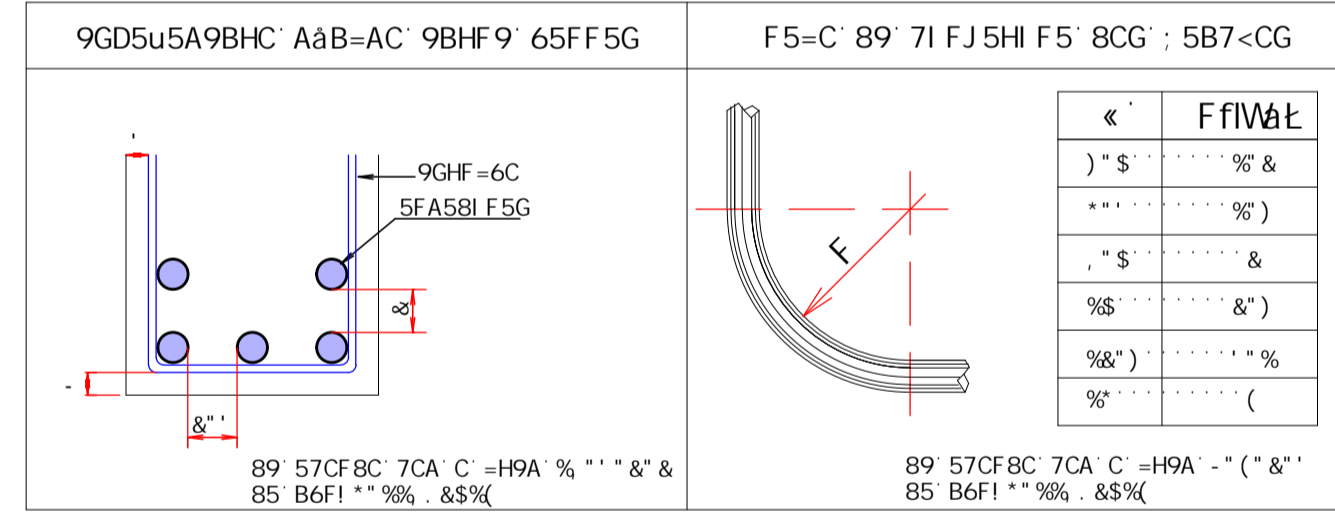
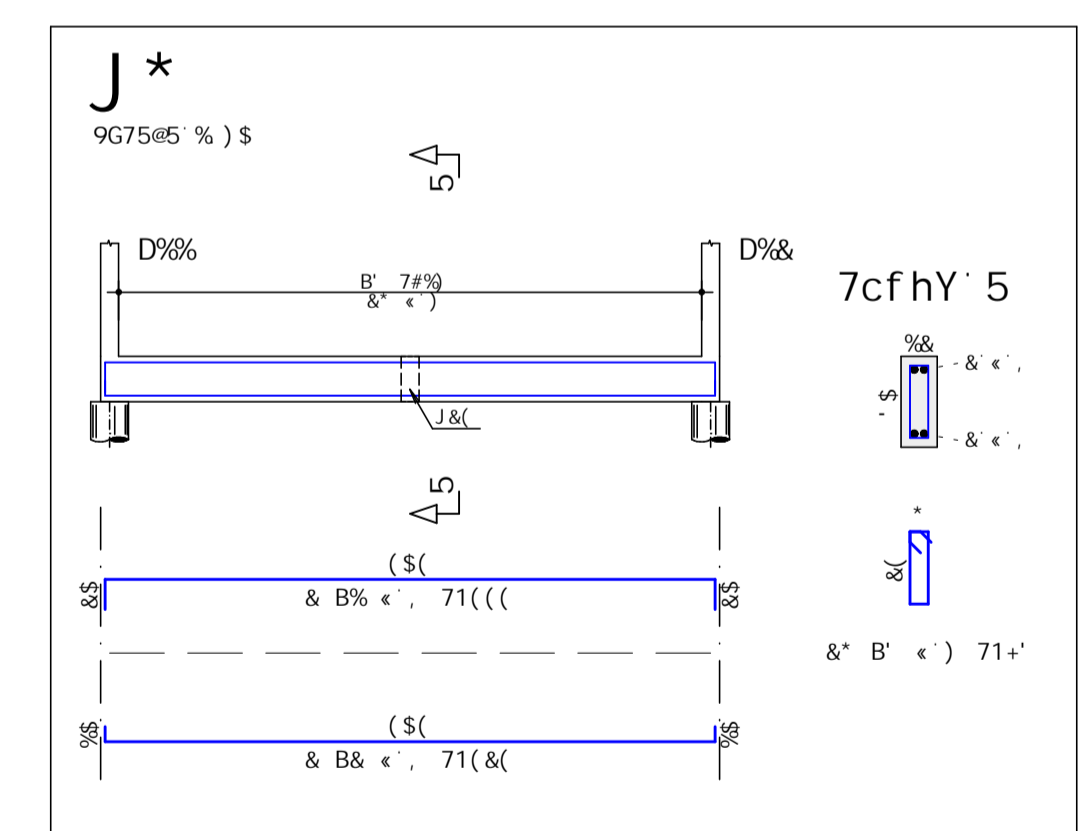
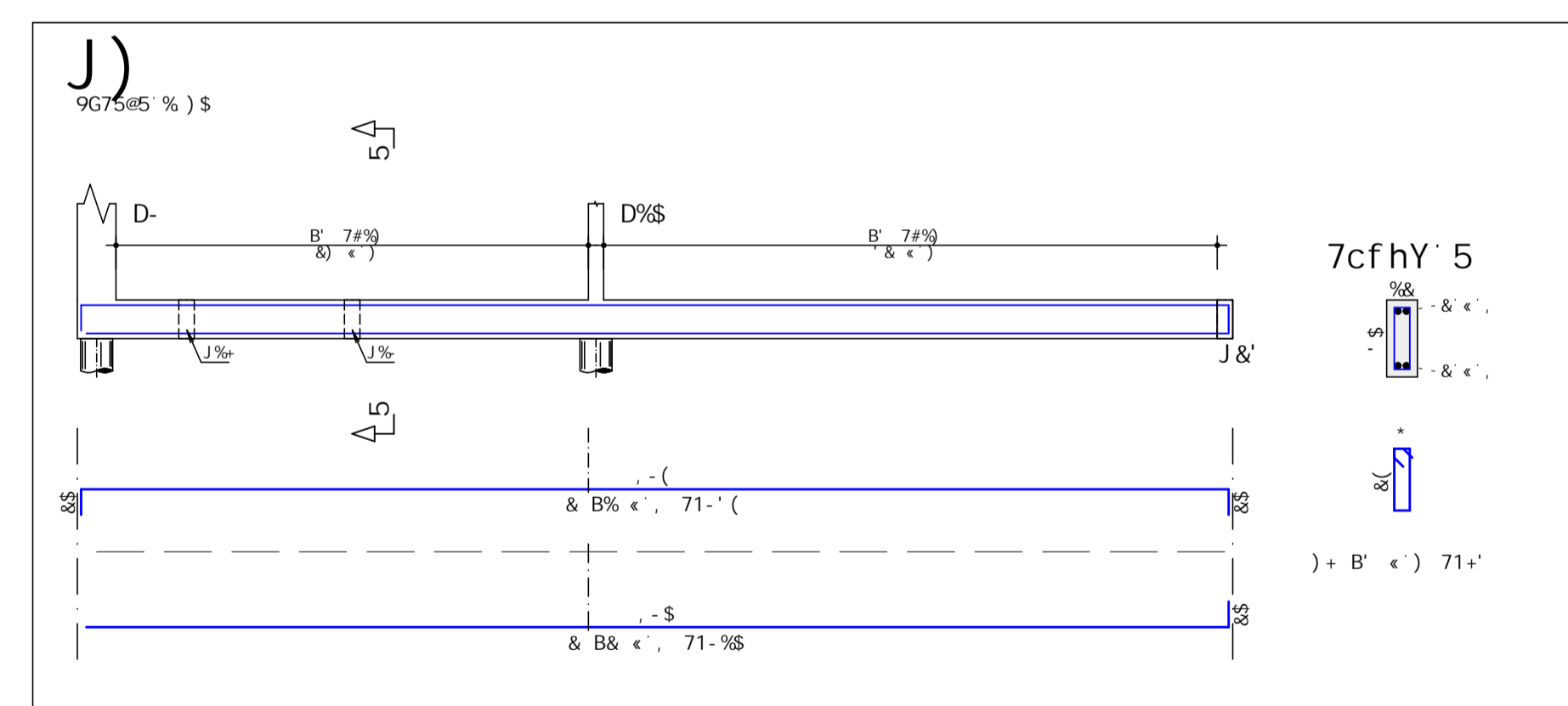
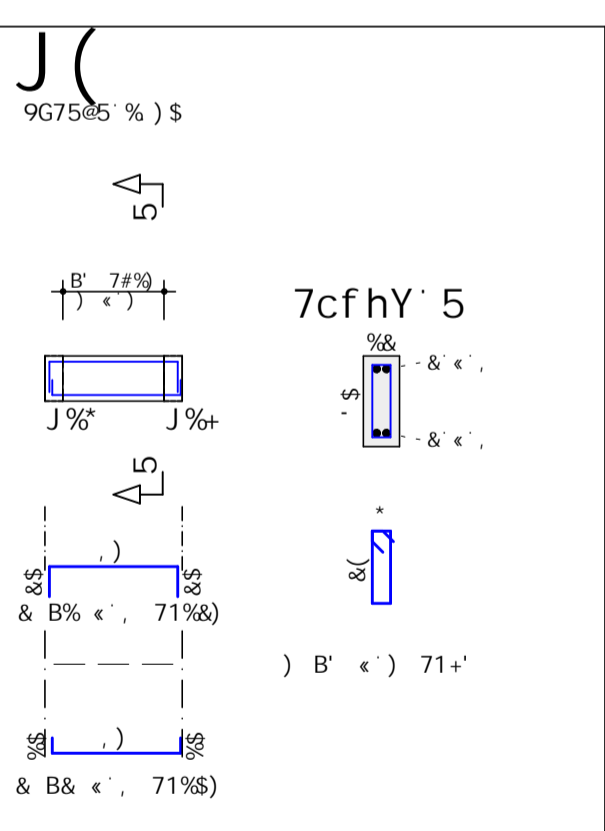

F9J	85H5	89G7F=u&C	9A=GGCF
F\$S	\$(#S) #&&&S	9A-G&C =B=7-5@	B9HC @9&C
F\$%	%(#S) #&&&S	F9J-G&C : 9F5@ =	B9HC @9&C
F\$Z	& #9&#&&&S	F9J-G&C : 9F5@ =Z	B9HC @9&C

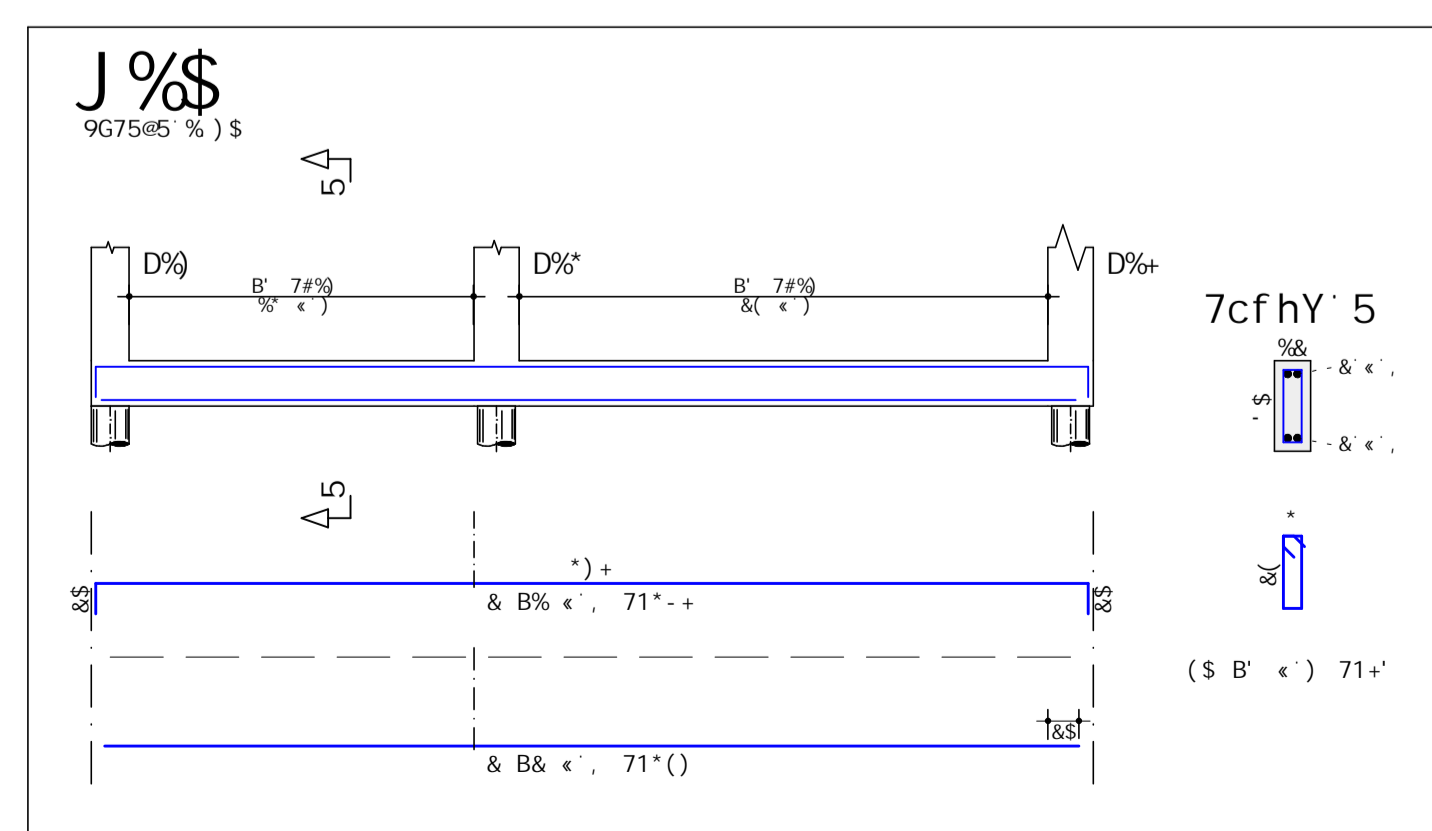
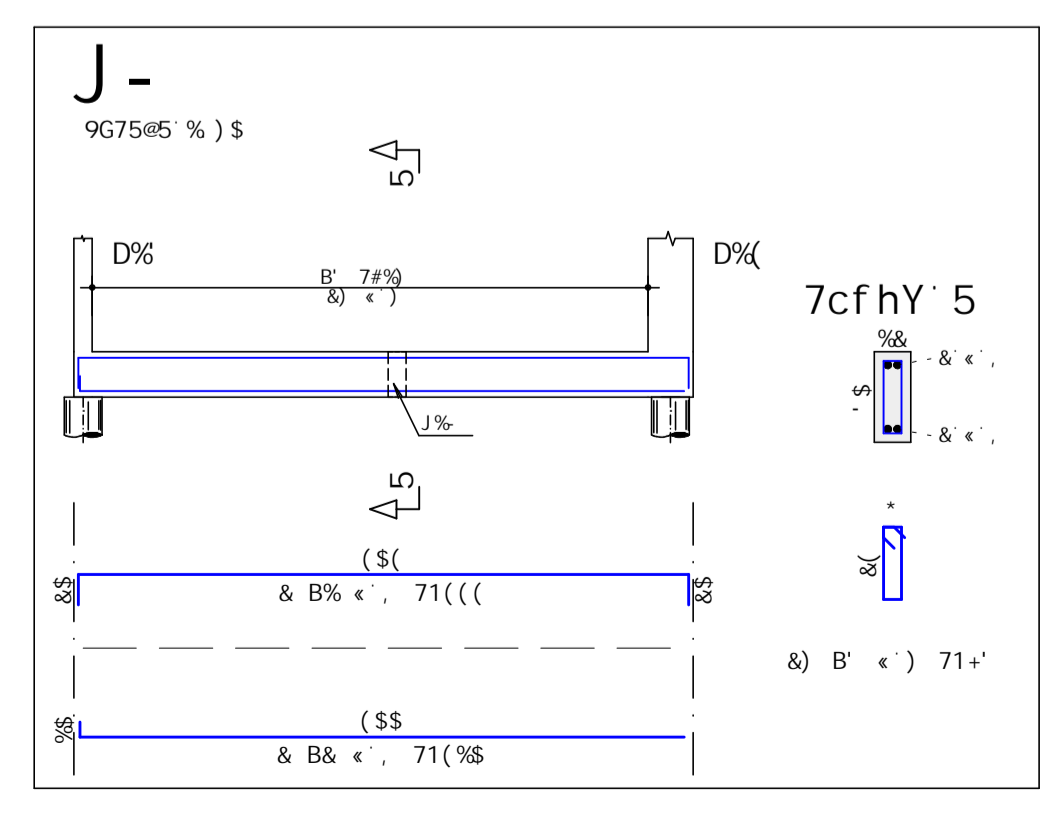
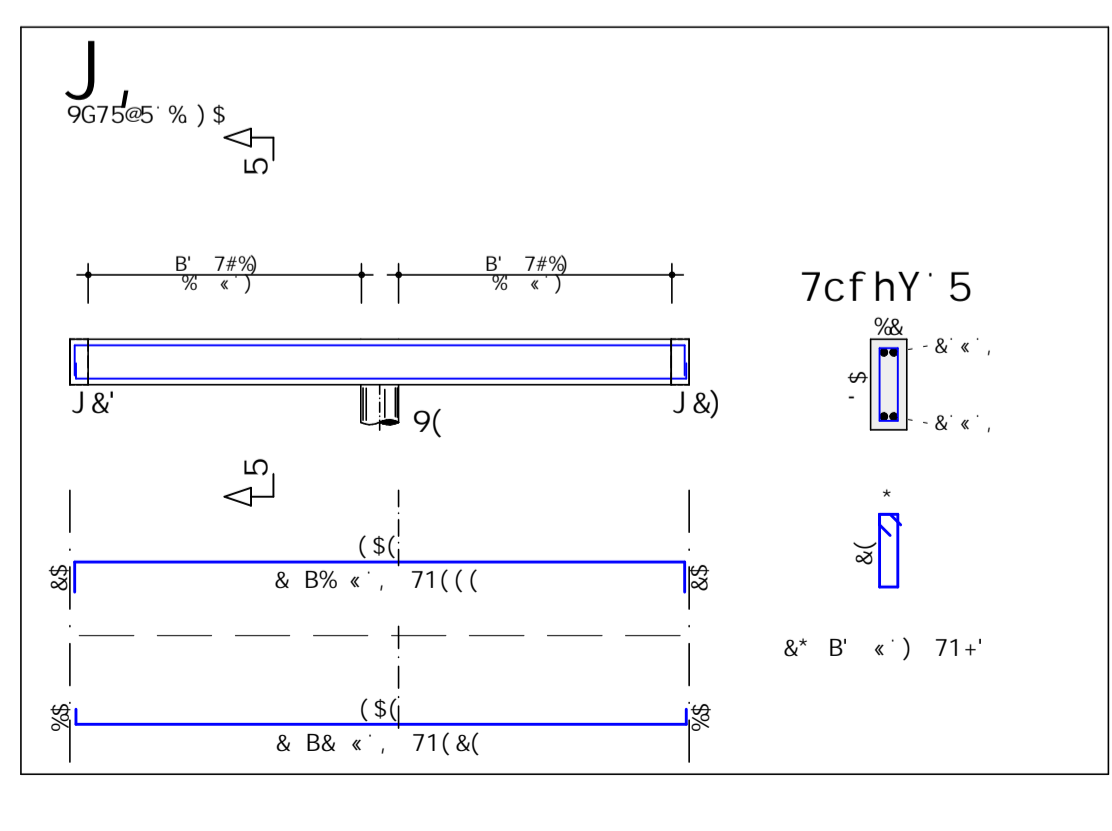
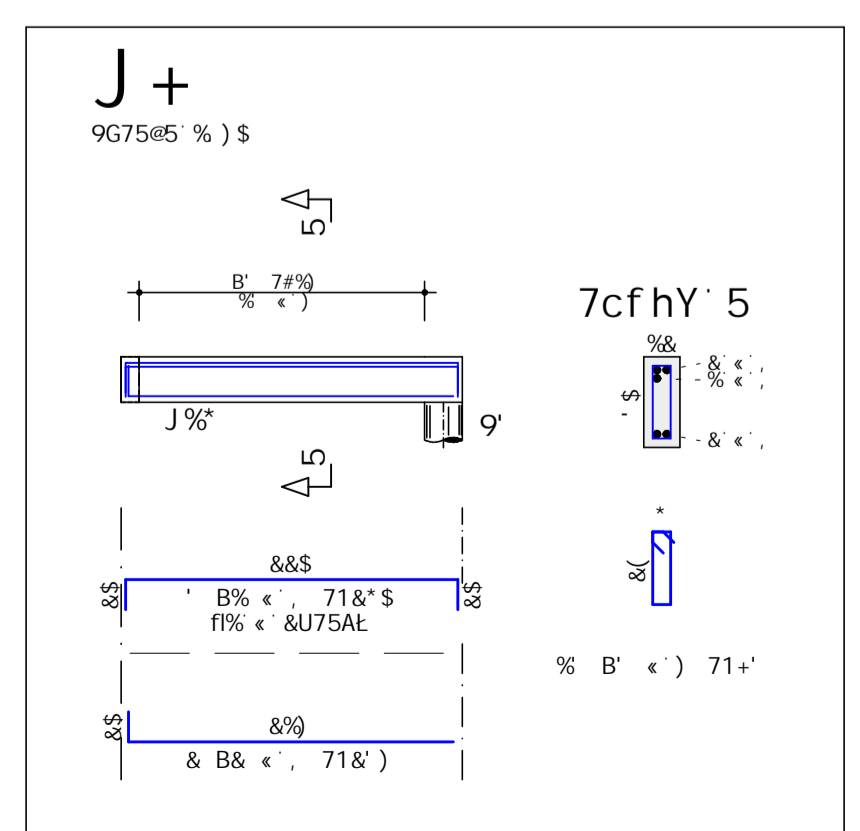

<p>C6F5</p> <p>H9F79=F5' =8589' F9G=89B7=5@ 7C<5D5F' =F5H' == ' ! && ' 9H5D5 9K5@8C' 7CF89=FC</p>	<p>7CBH9I 8C</p> <p>E</p> <p>9GH</p>
<p>DFCDF=9H&F=C</p> <p>DF 9' 9=H F5' AI B=7=D5@ 89' =F5H=1' DF</p> <p>F9GD' DFC-9HC</p> <p>DSI @C 657=@85' 75I' %& %&(1)</p> <p>F9GD' H7B=7C</p> <p>DSI @C 657=@85' 75I' %& %&(1)</p>	<p>DF5B7<5 B.</p> <p>\$'</p> <p>#\$,</p>
<p>89G9BI C&I -A9BHC DFC-'</p> <p>B9HC @9&C</p>	<p>89H5@<5A9BHC DFC-'</p> <p>B9HC @9&C</p>
<p>5GGI BHC</p> <p>DFC-'' 9GH575 F5@ 1' 6&G=7C</p> <p>9G75#5</p> <p>7CBH9I 8C</p> <p>AD= GC7=5@</p> <p>5FA5uC 85G 9GH575G/ 5FA5uC 85G 65#BF5A9G QJ 5H' J %&Q</p>	<p>9G75#5</p> <p>9G75#5</p> <p>9G75#5</p>
<p>TERCASA</p> <p>CONSTRUORA</p>	